

03 VÁLVULA BOLA PVC



• Bridas

CONSTRUCCIÓN

- 1 - Maneta/Palanca: PVC
- 2 - Juntas: EPDM
- 3 - Bola: PVC
- 4 - Juntas de cierre: EPDM
- 5 - Cuerpo: PVC
- 6 - Brida: PVC
- 7 - Manguitos: PVC
- 8 - Tornillo: ABS
- 9 - Eje: PVC

CONDICIONES DE TRABAJO

- Temperatura máxima: 60°C
- Presión máxima de servicio: 10 bar

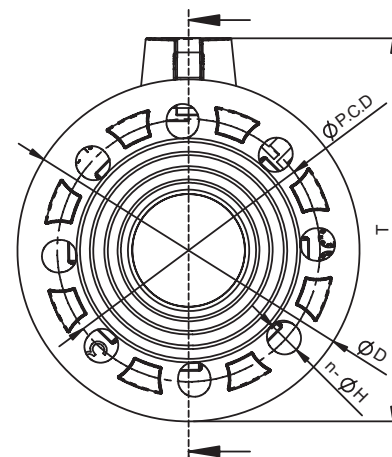
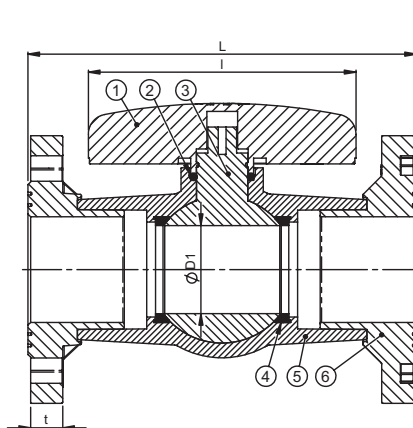

• DN-15 a DN-80 - Dimensiones (mm)

Código	Medida	Ø D1	T	t	L	l	ØD	ØP.C.D.	n-ØH
AA 03 361	DN-15	15	95	14	132	70	95	65	4-14
AA 03 362	DN-20	20	100	15	159	80	100	75	4-14
AA 03 363	DN-25	25,5	125	15	173	95	115	85	4-14
AA 03 364	DN-32	31	138	16	187	110	135	100	4-18
AA 03 365	DN-40	35	145	18	209	127	150	110	4-18
AA 03 366	DN-50	45	160	20	216	135	165	125	4-18
AA 03 367	DN-65	58	210	23	313	200	185	145	4-18
AA 03 368	DN-80	66	219	24	290	200	200	160	8-18

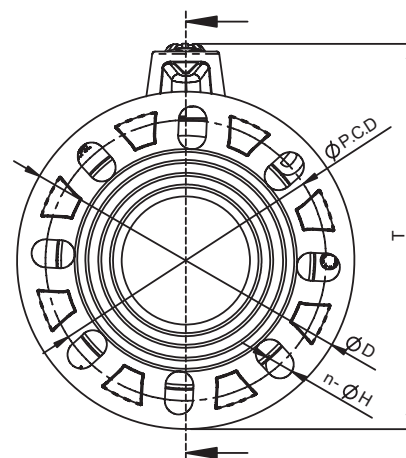
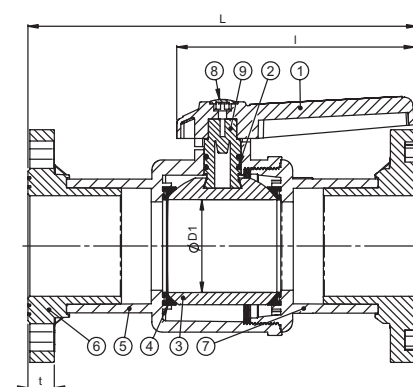

• DN-100 a DN-150 - Dimensiones (mm)

Código	Medida	Ø D1	T	t	L	l	ØD	ØP.C.D.	n-ØH
AA 03 369	DN-100	91,5	260	24	381	233,9	229	180	8-19
AA 03 370	DN-150	125	342	26	562	293,2	280	240	8-23