

13 QUEMADORES A GASÓLEO
B-50 / B-60 (de 204.000 a 918.000 Kcal/h)

Mod.	A	B	ØC	ØD	E	F	G	H	I	J	ØK	ØL
B-50-2F/B-50-3F	240	520	218	134	350	555	296	375	380	14	134	200-260
B-60-2F/B-60-3F	290	595	250	155	413	610	321	400	405	14	160	226-295

Características técnicas:

Modelo	B-50-2F	B-50-3F	B-60-2F	B-60-3F
Código	CE 13 210	CE 13 211	CE 13 212	CE 13 213
Potencia Kw	237 - 700		344 - 1.067	
Potencia Kcal/h	204.000 - 602.000		296.000 - 918.000	
Consumo Kg/h	20 - 59		29 - 90	
Motor V/Hz/W	400 / 50 - 60 / 750		400 / 50 - 60 / 1100	
Caja de control	BENTONE LANDIS			
Bomba	Suntec			
Cierre aire	Servomotor			
Regulación aire	2 Etapas	3 Etapas	2 Etapas	3 Etapas
Regulación línea boquilla	Manual	Hidráulica	Manual	Hidráulica
Nº Boquillas	2	3	2	3
Presión bomba Kg	14			
Normativa	EN267			
Peso bruto Kg	49		50	
Volumen m³	0,22		0,30	

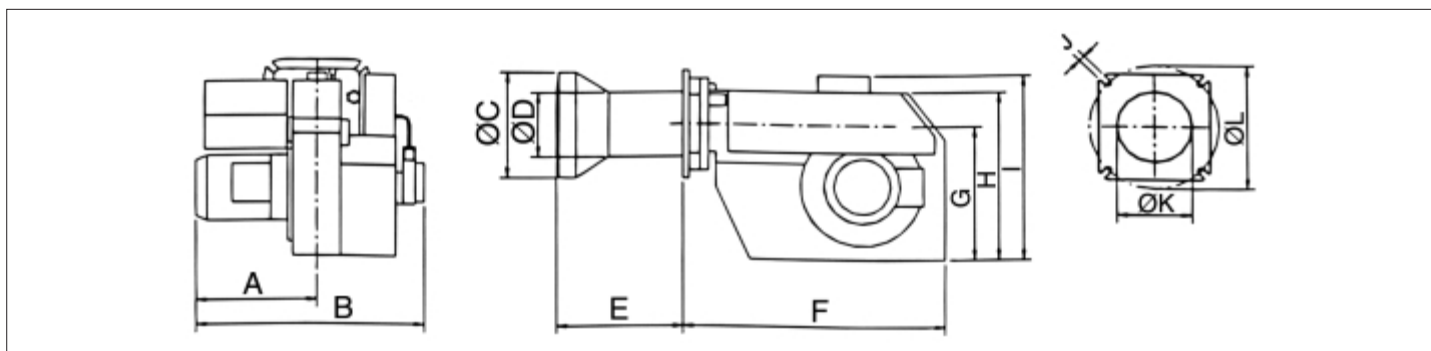
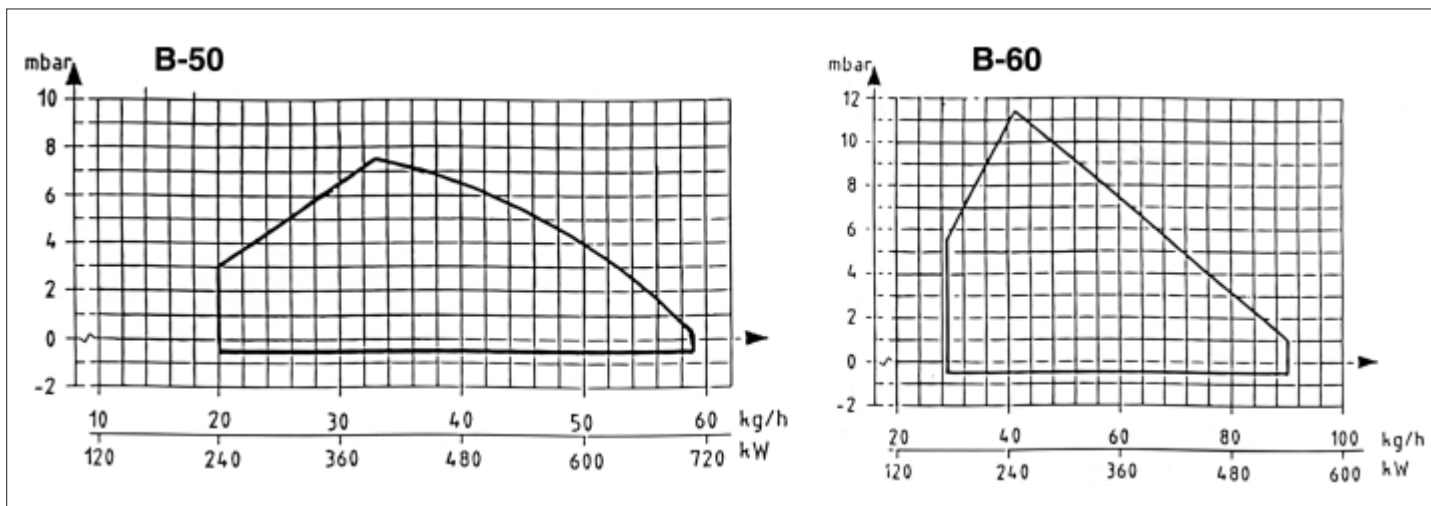