

MUNDOCLIMA®

Series 2000 Multisplit 2x1



COOL ONLY:

MUP-07X2CN

MUP-09X2CN

MUP-12X2CN

MUP-12+9CN



HEAT PUMP:

MUP-07X2HN

MUP-09X2HN

MUP-12X2HN

MUP-12+9HN

User's manual

The instructions before use

WARNING

Electric wiring must be installed according to relevant electrical safety rules and regulations.

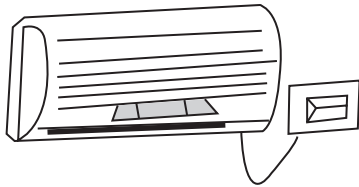

Don't damage the power cord or use an extended cord.

It can cause electric shock or fire.

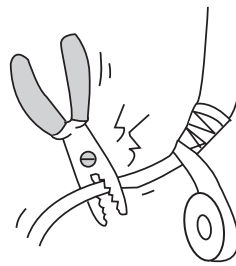

Don't operate the unit with wet hands.

It can cause electric shock.



Don't insert your hands or something else into the air intake or outlet vents.

It can cause danger.



Don't apply the cold wind to the body for a longtime.

It cause the physical condition deterioration and health problems.



When having a burning smell or smoke, please turn off the power supply and contact with the Service center of MUNDOCLIMA.



Don't attempt to repair the air conditioner by yourself.

You may cause further malfunctions.

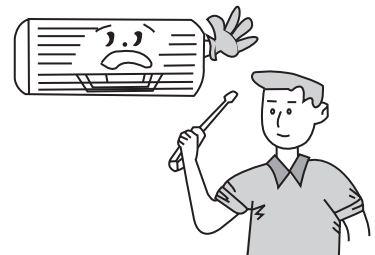

Don't use fuse excluding the fuse of correct capacity.

Improper wire could cause the break down or fire.

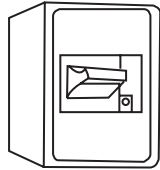

Be sure to shut down power supply if not using the Air Conditioner for a longtime.

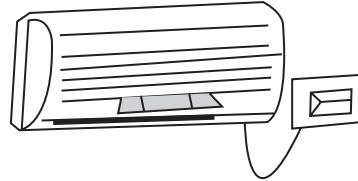

Don't place a space heater near the unit.

Air flow from the outlet can cause incomplete combustion.



Keep combustible spray away from the units.

It is likely to ignite.

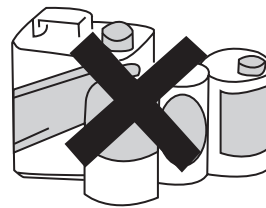

Please note whether the installed stand is firm enough or not.

It leads to the fall of the unit causes the injury etc. occasionally.

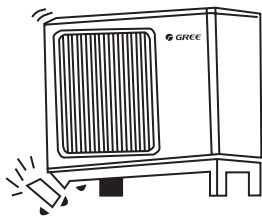

Don't step on the top of the outdoor unit.

As falling off the outdoor unit can be dangerous.

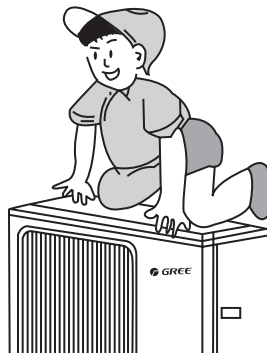

Don't block the air intake or outlet vents of both the outdoor and indoor units.

It can decrease the air conditioning capacity or cause a malfunction.

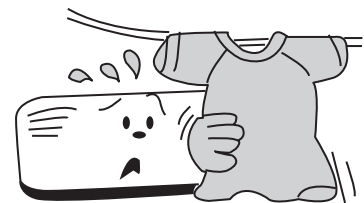

NAME AND FUNCTION OF EACH PART

Indoor unit

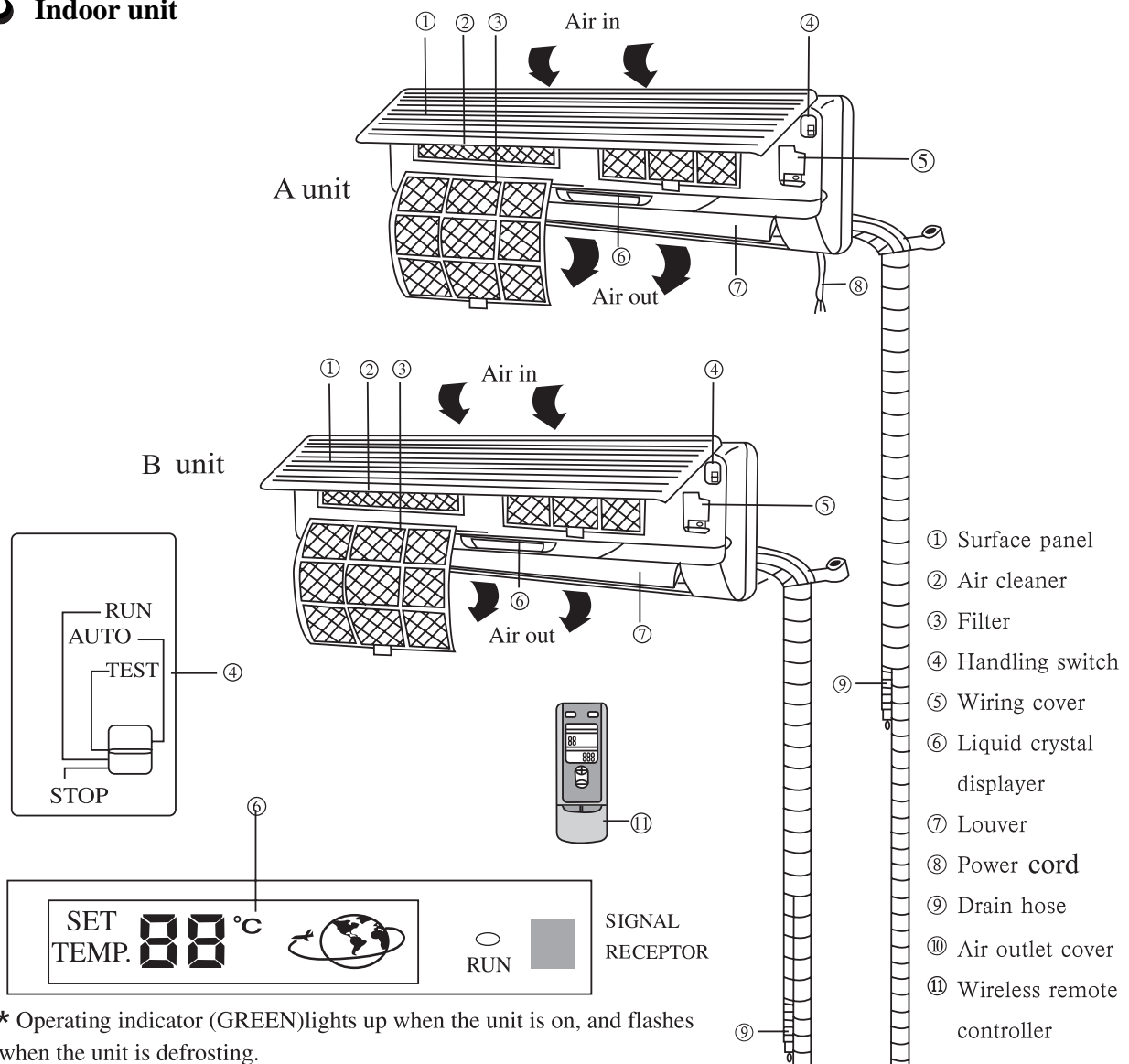

Outdoor unit

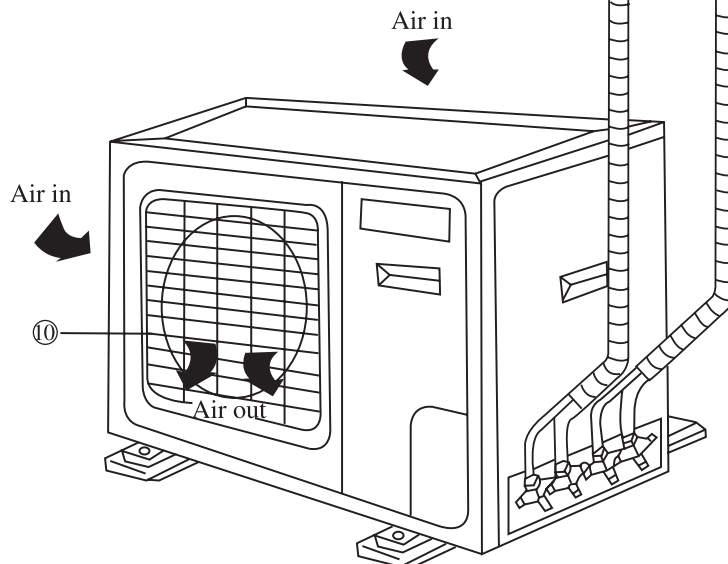

Remote control operation procedure

● Name and Function-Remote control

Note:

- Be sure that there are no obstructions.
- The remote control signal can be received at a distance of up to about 10m.
- Don't drop or throw the remote control.
- Don't place the remote control in a location exposed to direct sunlight.

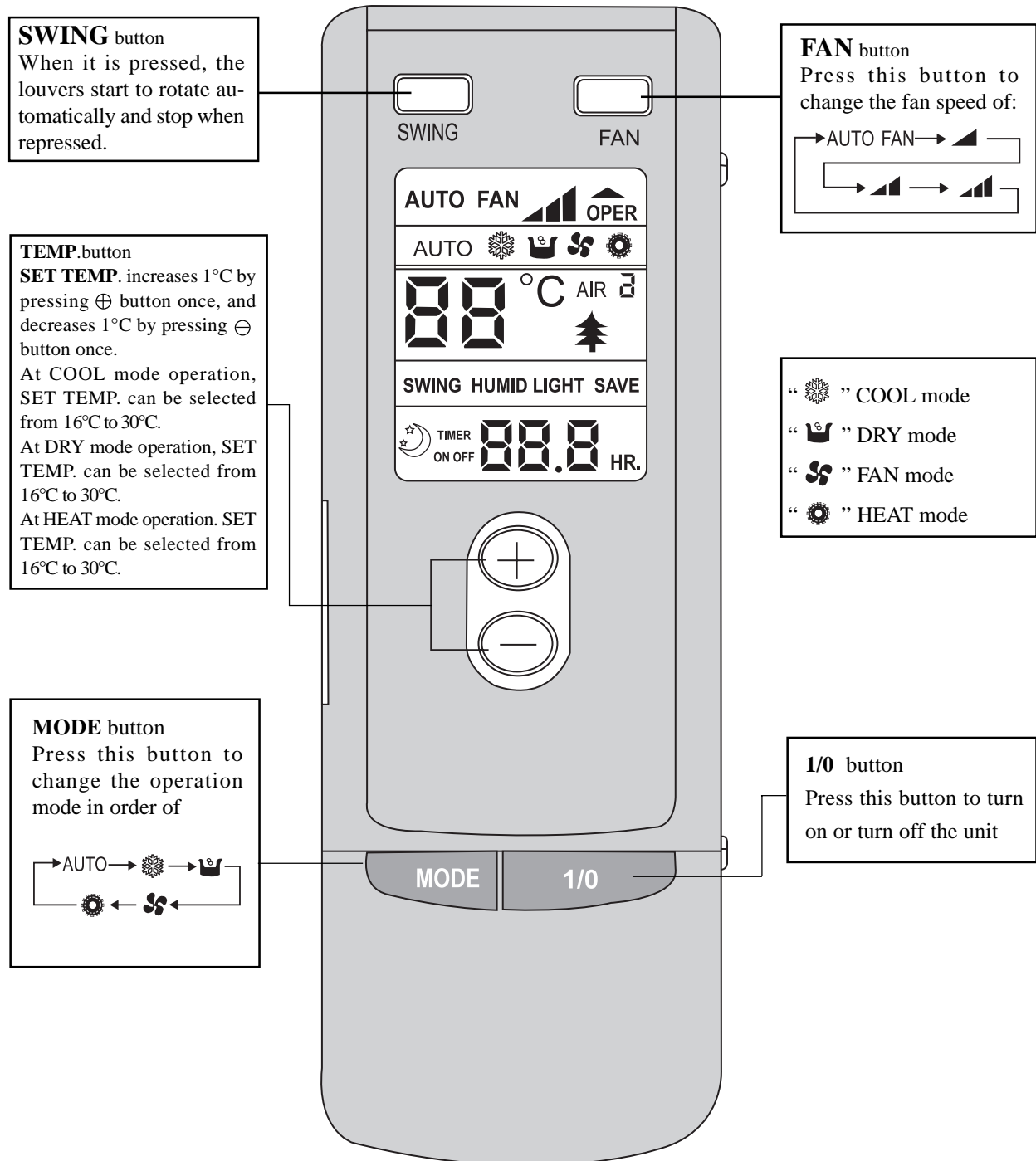

● Name and Function-Remote control. (Remove the cover)

Note: This type of remote controller is a kind of new current controller. some buttons of the controller which are not available to this Air conditioner will not be described below.

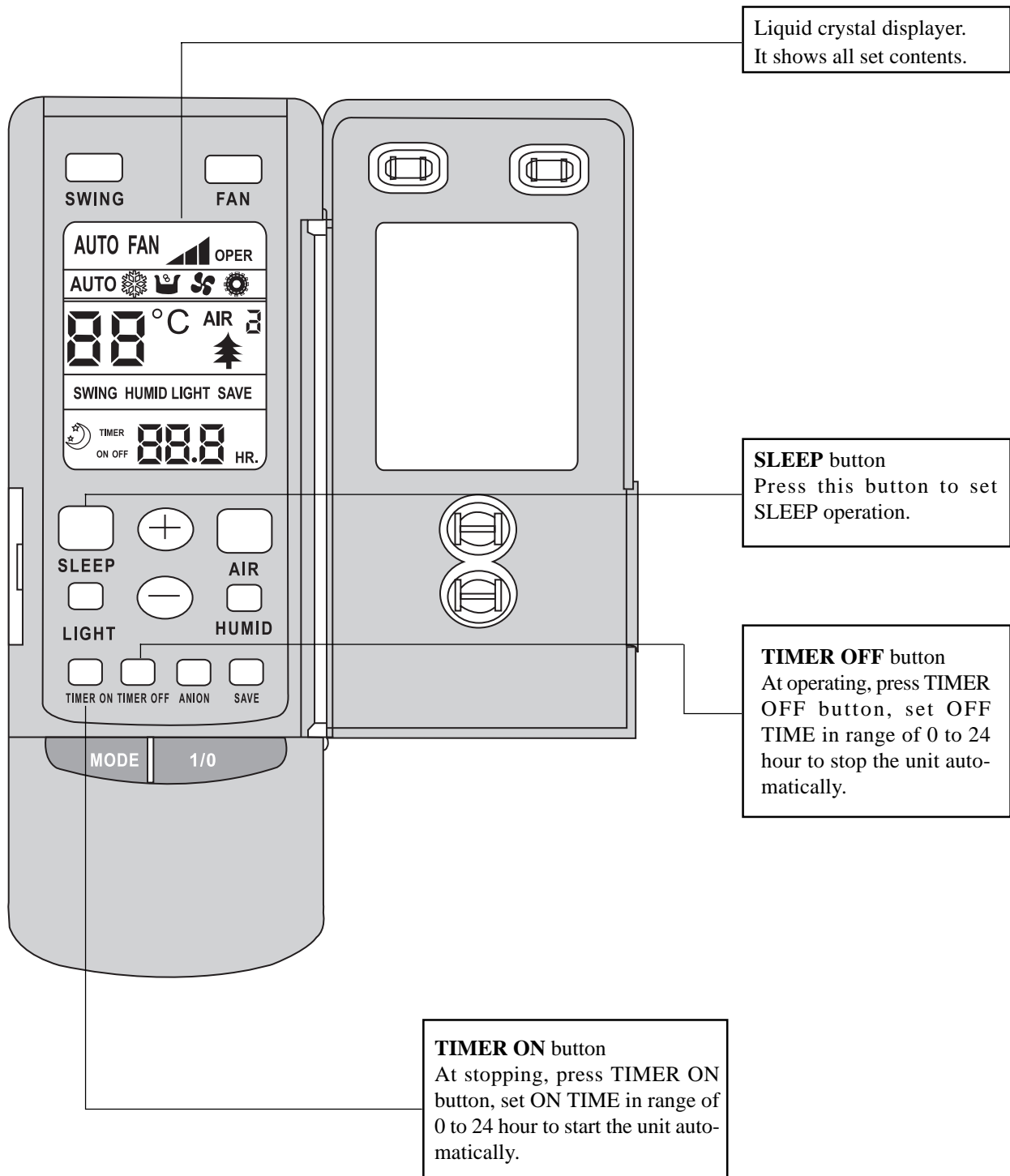

● COOL mode operation procedure

- According to difference between room temp. and set temp., microcomputer can control cooling on or not.
- If room temp. is higher than set temp., compressor runs at COOL mode.
- If room temp. is lower than set temp., compressor stops and only indoor fan motor runs.
- SET TEMP. should be in range of 16°C to 30°C.

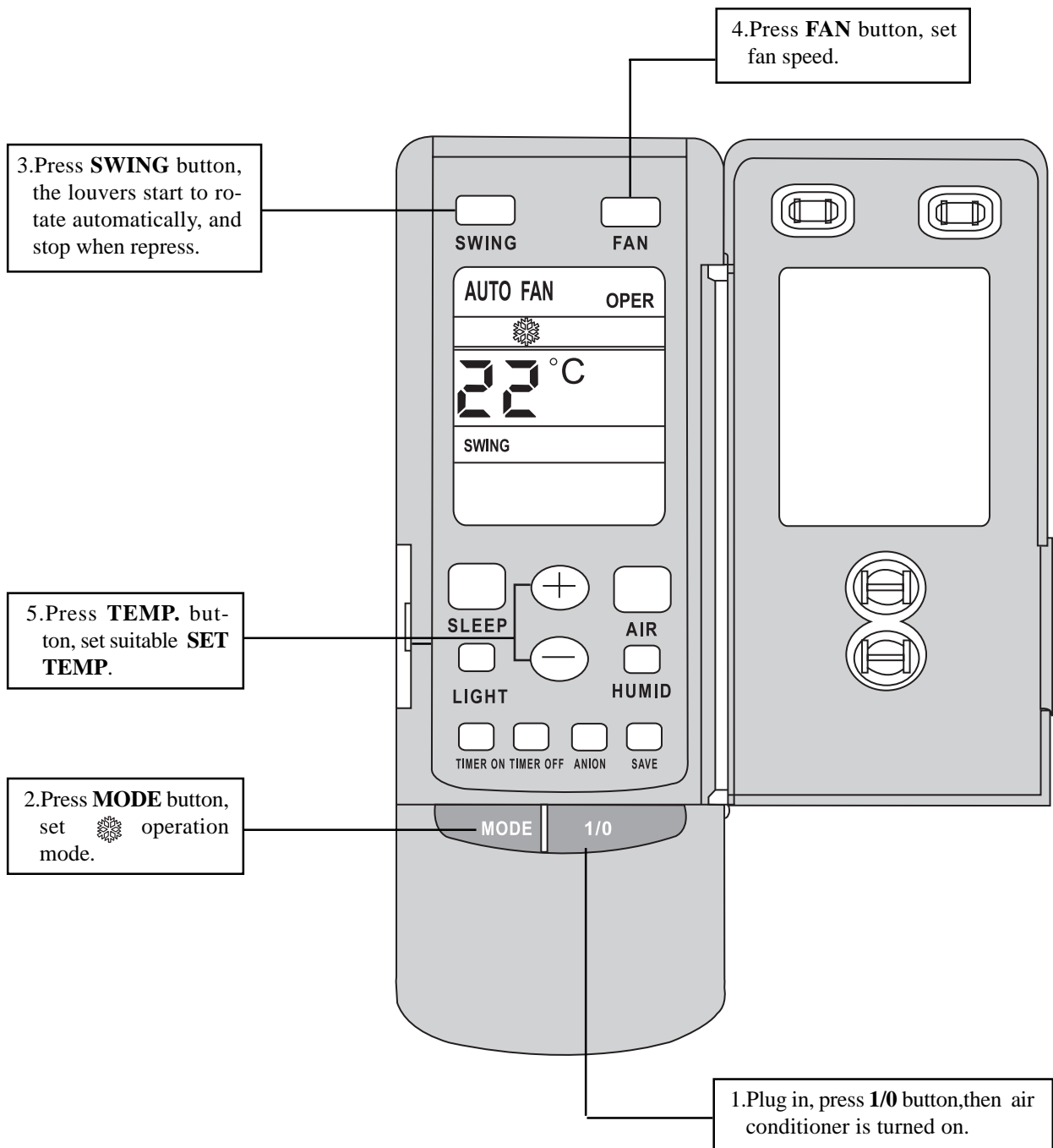

● HEAT mode operation procedure

- If room temp. is lower than set temp., compressor runs at **HEAT** mode;
- If room temp. is higher than set temp., compressor and outdoor fan motor stop, only indoor fan motor runs.
- **SET TEMP.** should be in range of 16°C to 30°C.

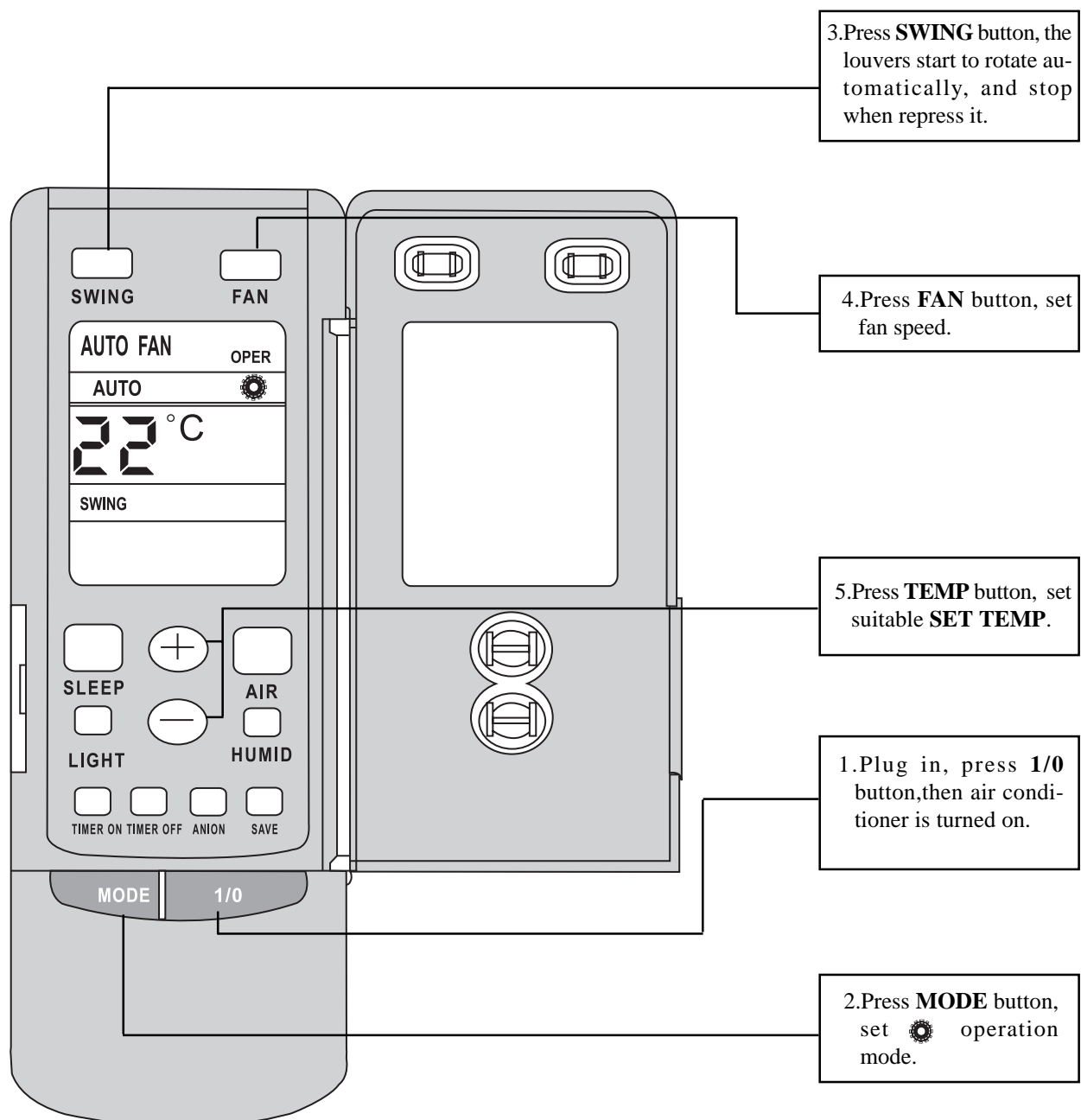

● DRY mode operation procedure

- If room temp. is lower than set temp., compressor, outdoor and indoor fan motor stop. If room temp. is between $\pm 2^{\circ}\text{C}$ of set temp., air conditioner is drying. If room temp. is higher than set temp., it's at COOL mode.
- SET TEMP. should be in range of 16°C to 30°C .

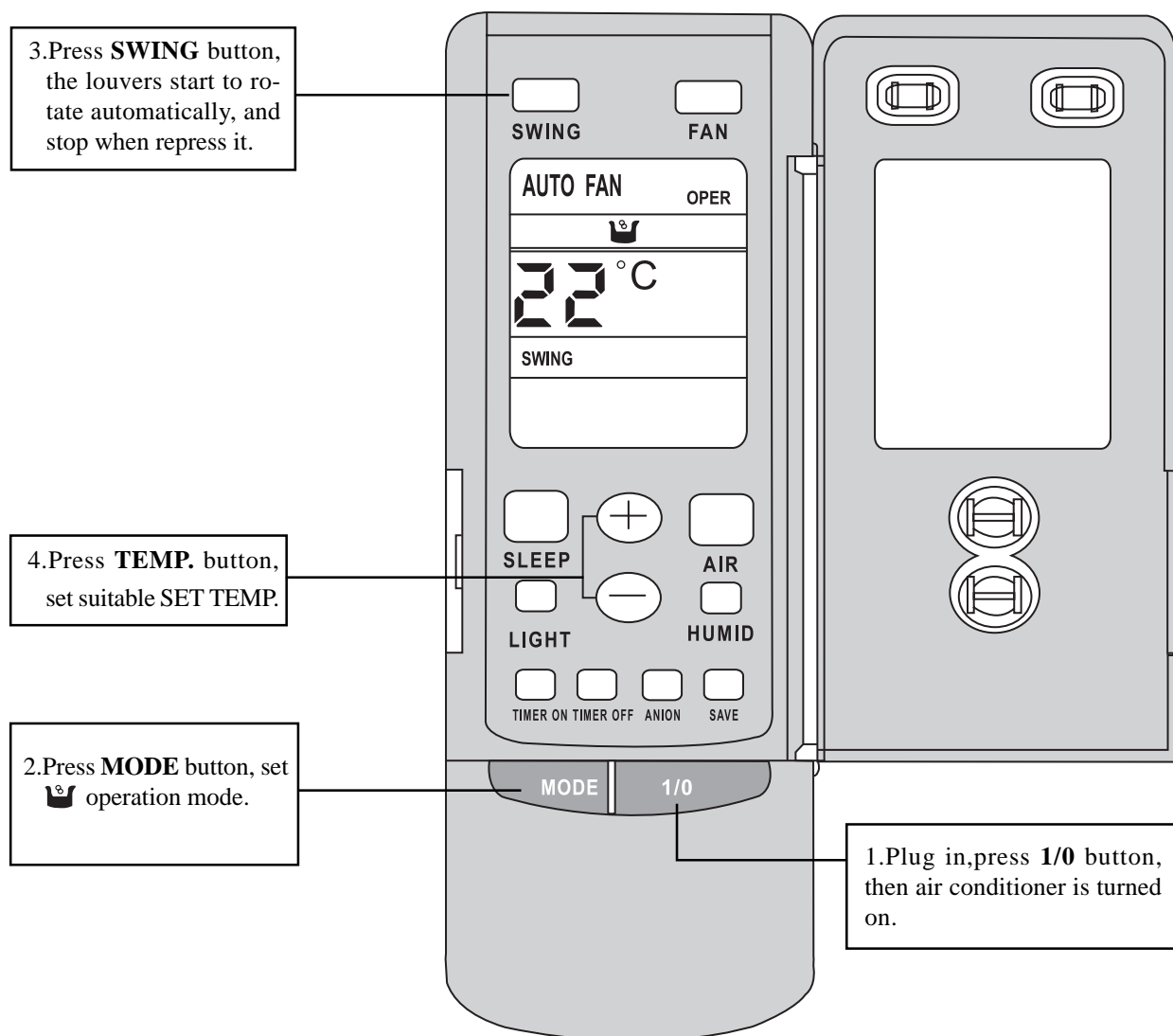

● **AUTO mode operation procedure**

- At AUTO mode operation, standard SET TEMP. is 25°C for COOL mode and 20°C for HEAT mode.

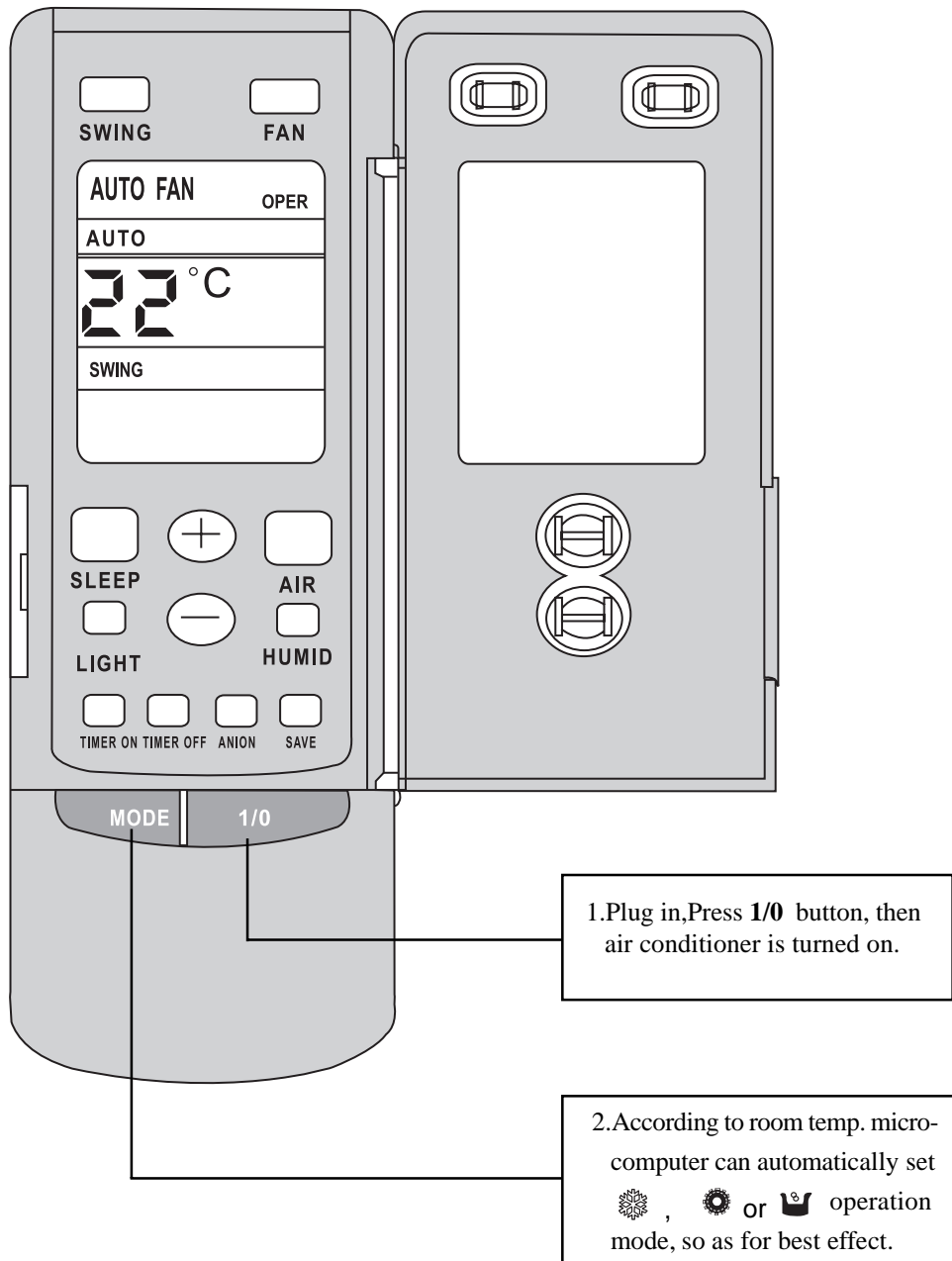

● TIMER mode operation procedure

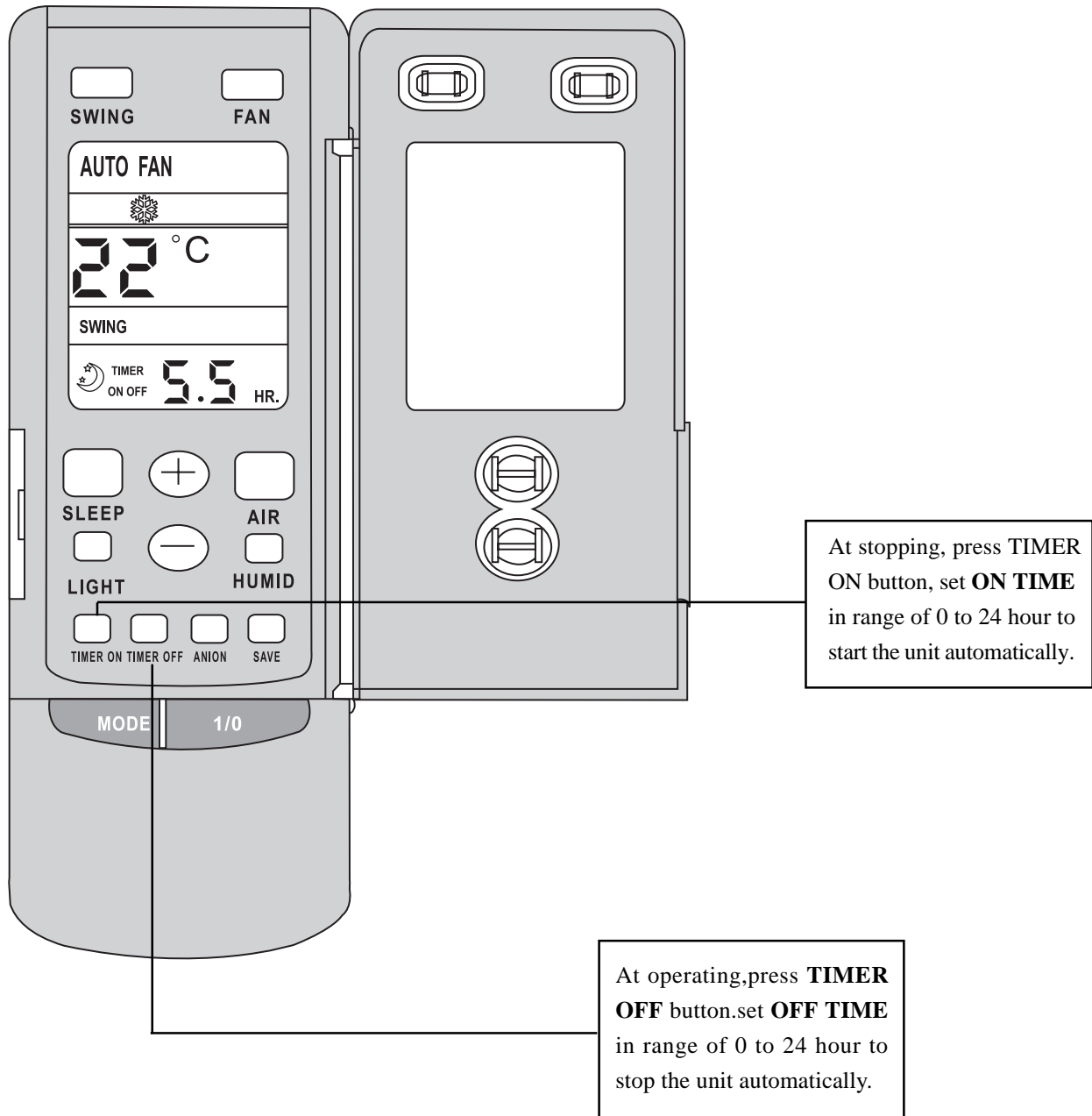

● SLEEP mode operation procedure

- When the unit is cooling or drying, if SLEEP operation is set, SET TEMP. would increase 1°C in 1 hour and 2°C in 2 hour. Indoor fan motor runs at low speed.
- When the unit is heating, if SLEEP operation is set, SET TEMP. would decrease 1°C, in 1 hour and 2°C in 2 hours. Indoor fan motor runs at low speed.

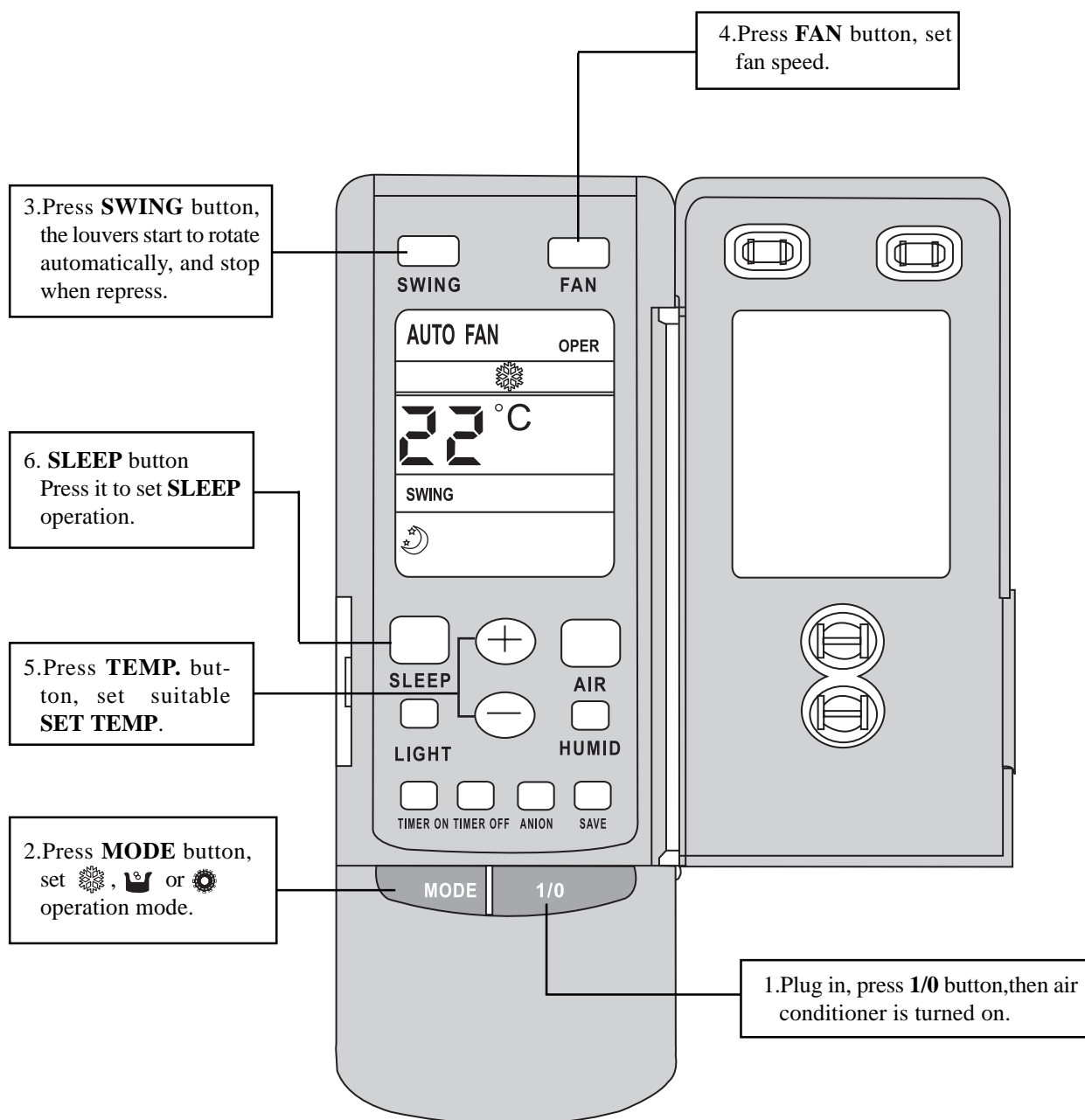

● How to install batteries

1. Remove the cover from the back of the remote control.
2. Insert the two batteries (Two AAA dry - cell batteries) and press button “ACL”.
3. Re - attach the cover.

NOTE:

- Don't confuse the new and worn or different batteries.
- Remove batteries when not in use for a longtime.
- The remote control signal can be received at a distance of up to about 10m.

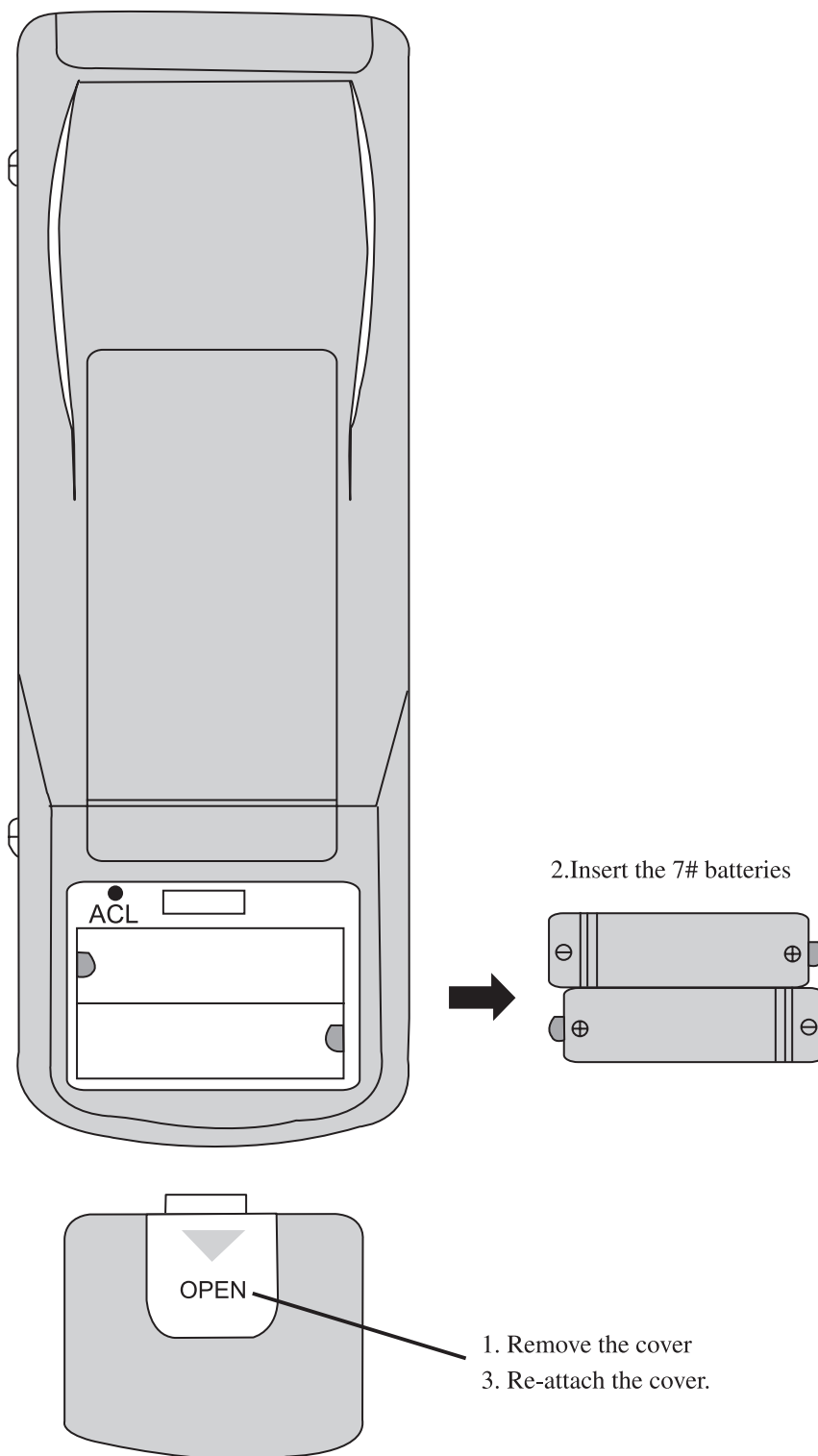

USER NOTICES

- **Select the most appropriate temperature.** It can preclude the electricity wasted.



- **The air flow direction can be adjusted appropriately.** The louvers can be adjusted downward at heating operation, and upward at cooling operation.

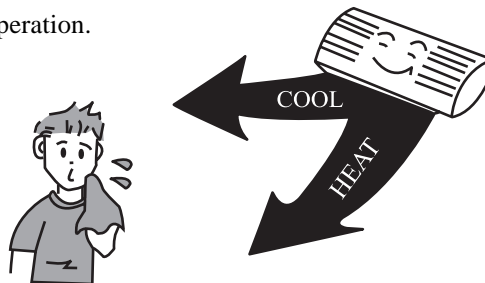

- **Don't leave windows and doors open while operating the air conditioner for a longtime.** It can decrease the air conditioning capacity.

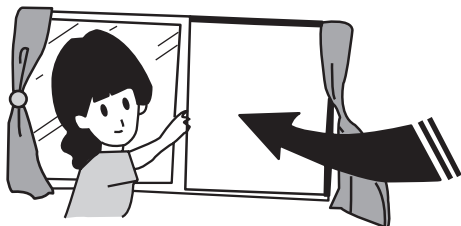

- **Don't blow the wind to animals and plants directly.** It can cause a bad influence to them.

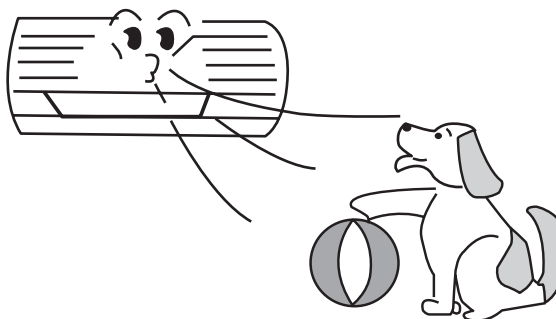

- **Splashing water on the air conditioner can cause an electric shock and mal-function.**

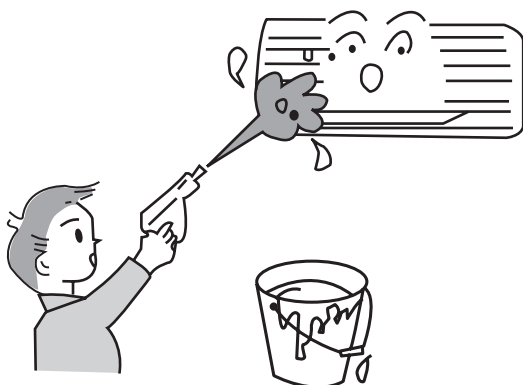

- **The ground must be connected.** Don't connect the earth wire to gas or water pipes, lightning rods or telephone earth lines.

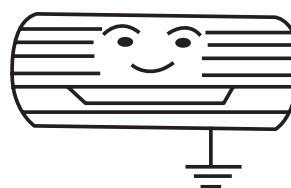

- **Air conditioner should be operated with stable voltage in range of 206 - 244V 1ph.** Otherwise, compressor would vibrate terribly to damage refrigeration system.

RATED VOLTAGE

220 - 230V~

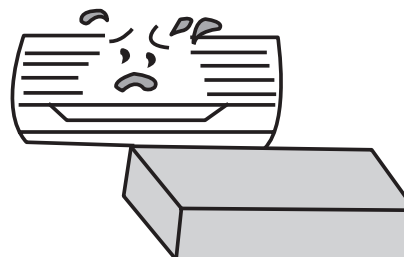

- **Don't use the air conditioner for other purposes,** such as drying clothes, preserving foods, etc.



Care and Maintenance

CAUTION

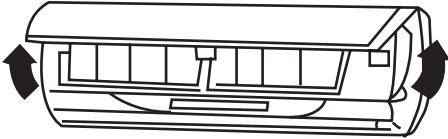
- Turn power off and pull out the power plug before cleaning air conditioner.
- Don't sprinkle water on the indoor unit and the outdoor unit for cleaning.
- Wipe the units with a dry soft cloth, or a cloth slightly moistened with water or cleaner.

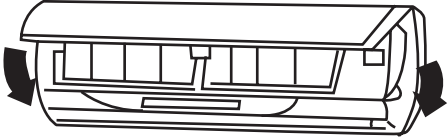
Cleaning surface panel	
1. Pull along the direction of arrows to take down surface panel.	
2. Washing Wipe with a cloth slightly moistened with water or cleaner, and then dry it in the shade. NOTE: Never use water above 45 °C to wash the panel, or it could cause deformation or discolouration.	
3. Install surface panel Cover the surface panel and clasp it.	

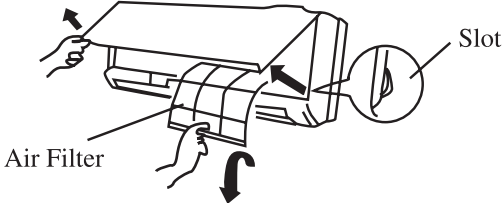
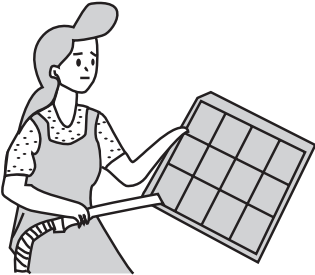
Cleaning the Air Filters (Recommended once every three weeks)	
1. Open the surface panel, hold the tab of Air Filter and raise it slightly, and then take it out.	
2. Cleaning To clear the dust adhering to the filters, you can either use a vacuum cleaner, or wash them with water and dry it in the shade. NOTE: • Never use water above 45°C to wash the filters, or it could cause deformation or discolouration.	

3.Reinsert the filters

Reinsert the filters with side marked “FRONT” facing forward.

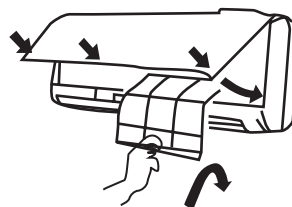

Installation of Air cleaner

1. Remove the Air Filters

(Refer to the first step of “cleaning the Air Filters”)

2. Install the Air cleaner.

Take off the packed bags of Air cleaners, and then put them into the filter frames.

Air cleaner



NOTE: Be careful not to injure yourself on the fins

3. Reinsert the filters.

(Refer to the third step of “cleaning the Air filters”)

Preparation before use

- 1.Be sure that nothing obstructs the air outlet and in-take vents.
- 2.Check that whether ground wire is properly connected or not.
- 3.Replace filters if necessary.

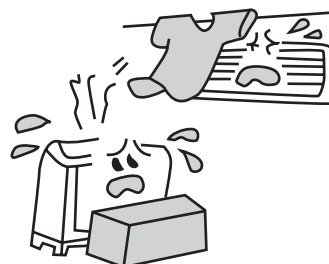





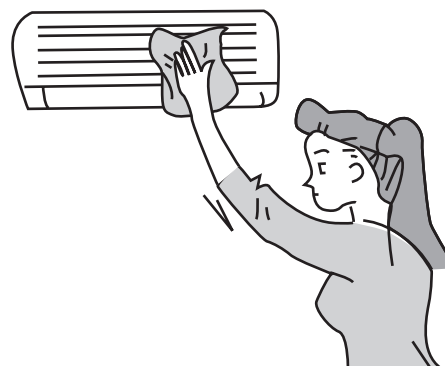

Maintain after use

- 1.Clean filters and other parts.
- 2.Turn main power off.
- 3.Clear dust from the outdoor unit.
- 4.Repaint the rubiginous place on the outdoor unit to prevent it from spreading.

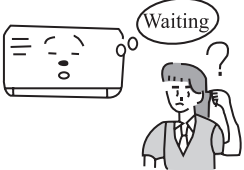

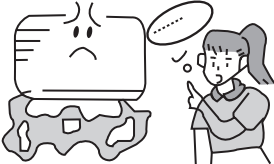
Troubleshooting

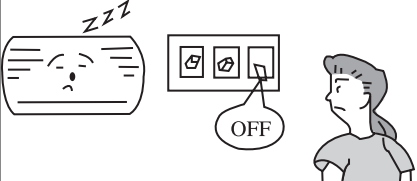
Check the following before requesting on service center if the malfunction occurs.

Phenomenon	Trouble Shooting
 <p>Indoor unit does not operate immediately when the air conditioner is restarted.</p>	<p>Once the air conditioner is stopped, it will not operate in approximately 3 minutes to protect itself.</p>
 <p>There's unusual smell blowing from the outlet after operation is started.</p>	<p>This is caused by the odors in the room which have been breathed into the air conditioner.</p>
 <p>Sound of water flow can be heard during operation.</p>	<p>This is caused by the refrigerant flowing inside the unit.</p>
 <p>Mist is emitted during cooling operation.</p>	<p>Because the air of the room is cooled down rapidly by the cold wind and it looks like the fog.</p>
 <p>Creaking noise can be heard when start or stop the unit.</p>	<p>This is caused by the deformation of plastic due to the change of temperature.</p>
 <p>Air conditioner does not operate at all.</p>	<ul style="list-style-type: none"> • Has the power been shut down? • Is the wiring loose? • Is the leakage protection switch in operation? • Is voltage higher than 244V or lower than 206V? • Is TIMER ON in operation?
 <p>Cooling (Heating) efficiency is not good.</p>	<ul style="list-style-type: none"> • Is SET TEMP. suitable? • Is air inlet or outlet obstructed? • Are air filters dirty? • Is indoor fan speed set at low speed? • Is there any other heat source in your room?
 <p>Wireless remote controller is not available.</p>	<ul style="list-style-type: none"> • Is the remote control unit out of effective distance to the indoor unit? • Replace the worn batteries of wireless remote controller. • Are there any obstructions between the wireless remote controller and the signal receptor?

Immediately stop all operations and plug out, contact with service center of MUNDOCLIMA in following situations.



- Unusual noise can be heard during operation.
- Power fuse or switch often breaks.
- Carelessly splash water or something into air conditioner.
- Electrical lines and power plug are very hot.
- Wind blowing from the outlet smells terrible during operation.

NOTE:

Equipment subject to notification to or consent by the supply authority before connection to the system (consent by the supply authority may be requested for high-power appliances which are intended to be used only in systems having impedances considerably lower than the reference impedance. General consent may be declared for use of a type of appliance in a defined part of the supply system):

1. Equipment intended exclusively for professional purposes;
2. Appliances and equipment without automatic control means;
3. Appliances producing less than one voltage change per hour;
4. Appliances producing more than 1800 voltage changes per minute;
5. Disturbances caused by manual switching.

Technical specifications











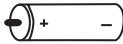

Model	MUP-07X2CN	MUP-07X2HN	MUP-09X2CN	MUP-09X2HN	MUP-12X2CN	MUP-12X2HN
Functions	Cool	Cool Heat	Cool	Cool Heat	Cool	Cool Heat
Accessory	Air cleaner					
Cooling capacity (W)	2000x2	2000x2	2500x2	2500x2	3500x2	3500x2
Heating capacity (W)	-	2300x2	-	2800x2	-	3800x2
Power supply	220-230V~50Hz					
Input Power (W)	950x2/-	950x2/950x2	1150x2/-	1150x2/1200x2	1650x2/-	1650x2/1500x2
Air Flow Volume (m ³ /h)	2x420				2x520	
Refrigerant	R-407C					
Noise (Indoor/Outdoor) dB (A)	34/34/56		35/35/56		38/38/58	
Climate type	T1					
Isolation	I					
Weight(kg) <small>Indoor unit/ Outdoor unit</small>	2x11/64kg				2x11/71kg	
Dimension(cm) (W x H x D)	Indoor unit: 83.0x28.5x18.9					
	Outdoor unit:95.0x70.0x34.0				Outdoor unit:95.0x84.0x34.0	

- All above are test according to CHINA NATIONAL STANDARD GB/T 7725-1996.
- All above should be changed without notice, there are latest and accurate specifications on the nameplate of your air conditioner.

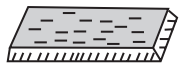
Working temperature range		
	Indoor side DB/WB (°C)	Outdoor side DB/WB (°C)
Maximum cooling	32/23	43/26
Minimum cooling	21/15	21/-
Maximum heating	27/-	24/18
Minimum heating	20/-	-5/-6

Accessories and Installation diagram

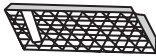
☉ Accessories (Check that all accessory parts are present before installation)

No.	Part name	Diagram	Qty	specification	Memo
1	Rear panel		2		
2	Wireless remote controller		2		
3	Battery		2	7# 1.5V	
4	Power connection cord		2		
5	Control cord		2	5x1.0	Heat pump type only
6	Tapping screw		2	ST4.2x25	Fix the rear panel
7	Plastics drain hose		2	L = 2m	Packaged with connection piping
8	Gum type sealer		2	120x65x25	
9	Piping-hole sleeve		2		Packaged with connection piping
10	Wrapping tape		2	30x10	Packaged with connection piping
11	Connection piping		2	∅6/∅9.5(12)	Packaged with connection piping
12	Thermal insulation hose		2	∅35x500	
13	Air cleaner		2		Packaged with indoor unit
14	Wire ring		1		

* Be sure to use the exclusive accessories list above in the installation, or it will lead to water leakage ,electric shock, fire, etc.

● Installation dimension diagram

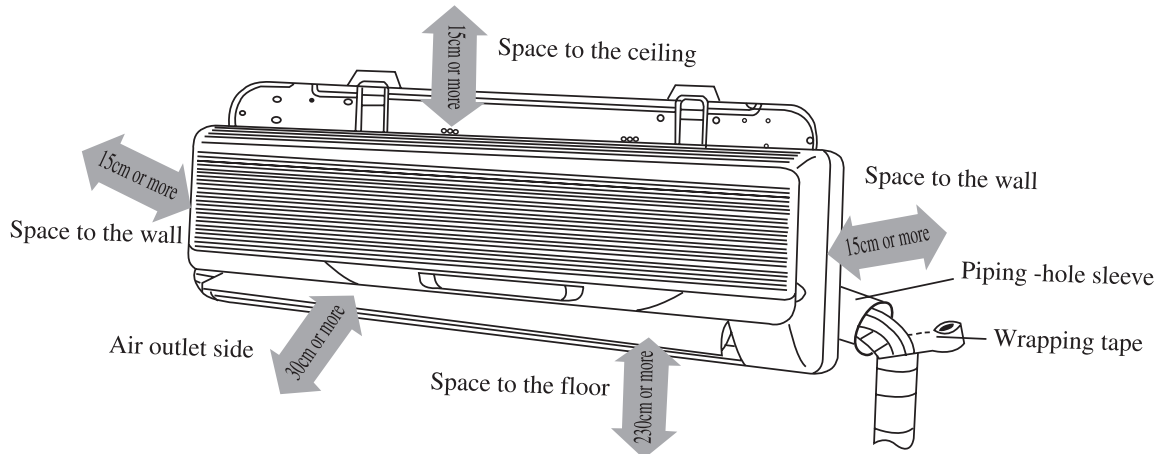

* The installation method of indoor units will be shown by one unit (A unit), that of the other unit (B unit) is the same unless special statement.

IMPORTANT NOTES

- * The installation must be done by trained and qualified service personnel with reliability according to this manual.
- * Contact with service center of MUNDOCLIMA before installation to avoid the mal-function due to unprofessional installation.
- * When picking up and moving the units, you must be guided by trained and qualified personal.
- * The distance between air outlet and the combustibile must be over 50cm if the heater element is equipped.

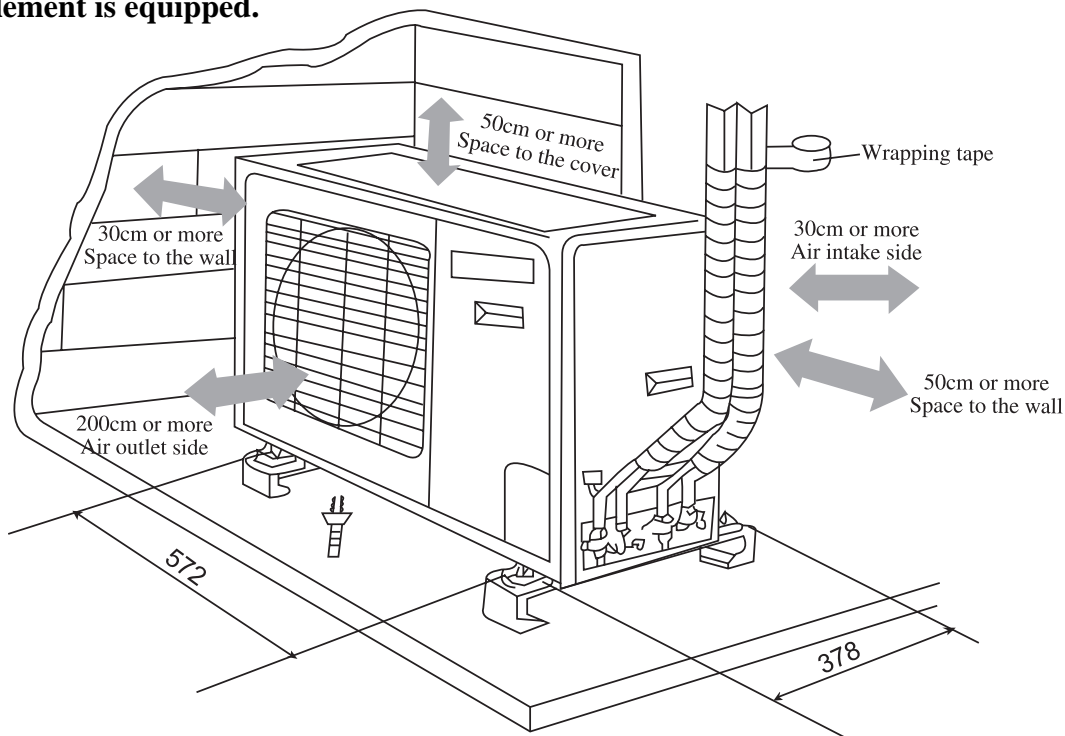

Installation location

● Indoor unit

1. The inlet and outlet should not be covered so that the outflow air can reach all parts of the room.
2. Install in a location where is permitting easy connection with the outdoor unit.
3. A location from which the condensation water can be drained out conveniently.
4. Avoid a location where there is heat source, high humidity or inflammable gas.
5. Install in a location where is strong enough to withstand the full weight and vibration of the unit.
6. Be sure that the installation conforms to the installation dimension diagram.
7. Be sure to leave enough space to allow access for routine maintenance.
8. Install in a location where is 1m or more away from other electric appliances such as television, audio device, etc.
9. Select location where is easy to remove and clean the filter.

● Outdoor unit

1. Select location from which noise and outflow air emitted by unit will not inconvenience neighbors.
2. Select location where there should be sufficient ventilation.
3. The inlet and outlet should not be covered.
4. The location should be able to withstand the full weight and vibration of the outdoor unit.
5. There should be no danger of flammable gas or corrosive gas leaks.
6. Be sure that the installation conforms to the installation dimension diagram.

NOTE:

Install in the following place may cause mal - function. If it is unavoidable, contact with service center of MUNDOCLIMA please.

- Place where oil (machine oil) is used.
- The place where a lot of salinities such as coast exists.
- Place where a sulfured gas such as the hot spring zones is generated.
- Place where high - frequency waves are generated by radio equipment, welders and medical equipment.
- Other place with special circumstance.



Install the indoor unit

● Install the rear panel

1. Always mount the rear panel horizontally.
2. Fix the rear panel on the selected location with screws supplied with the unit.
3. Be sure that the rear panel has been fixed firmly enough to withstand the weight of an adult of 60kg, furthermore, the weight should be evenly shared by each screw.

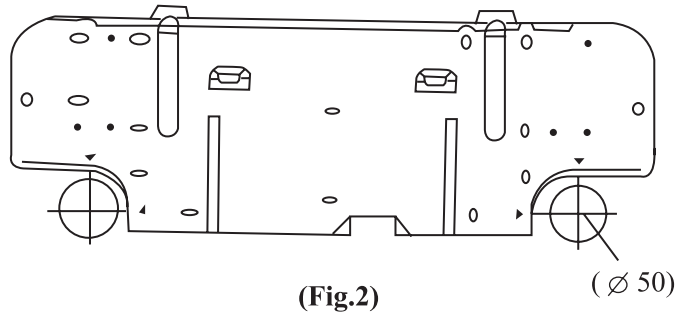

● Install the drain hose

1. For well draining, the drain hose should be placed at a downward slant.
2. Do not wrench or bend the drain hose or flood its end by water.

● Install the piping hole

1. Make the piping hole (∅50) in the wall at a slight downward slant to the outdoor side.
The center of the hole should be determined refer to Fig.2.
2. Insert the piping-hole sleeve into the hole to prevent the connection piping and wiring from being damaged when passing through the hole.

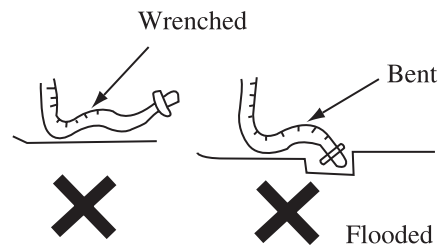

● Install the connection pipes

Connect the connection pipes with the relevant union pipes of the indoor unit (Shown in P25 “Install the connection pipes”)

NOTE:

- Connect the connection pipes with the indoor unit firstly and the outdoor unit secondly.
- Be careful in bending the connection pipes, or you will damage the pipes.
- If the tightening torque is too great in tightening the flare nuts, leakage will happen.

● Electrical wiring

1. Open the surface panel.
2. Remove the wiring cover.
3. Route the power connection cord from the back of the indoor unit and pull it toward the front through the wiring hole for connection.
4. Connect the blue wire of the power connection cord to the terminal “N(1)”, the brown one to “2”, the red one to “3”, and the yellow- green one (earth wire) to “⊥” as shown in Fig.3. For the heat pump type, a control cord (5x1.0) should be connected to the indoor unit through the wiring interface.
5. Reassemble the wiring cover.
6. Recover the surface panel.
7. For the heat pump type, fix the control cord on the chassis with clamp.
8. Directly connected the power cord of A unit to the supply terminals and shall have a contact separation of at least 3mm in each pole. (B unit has no power cord)

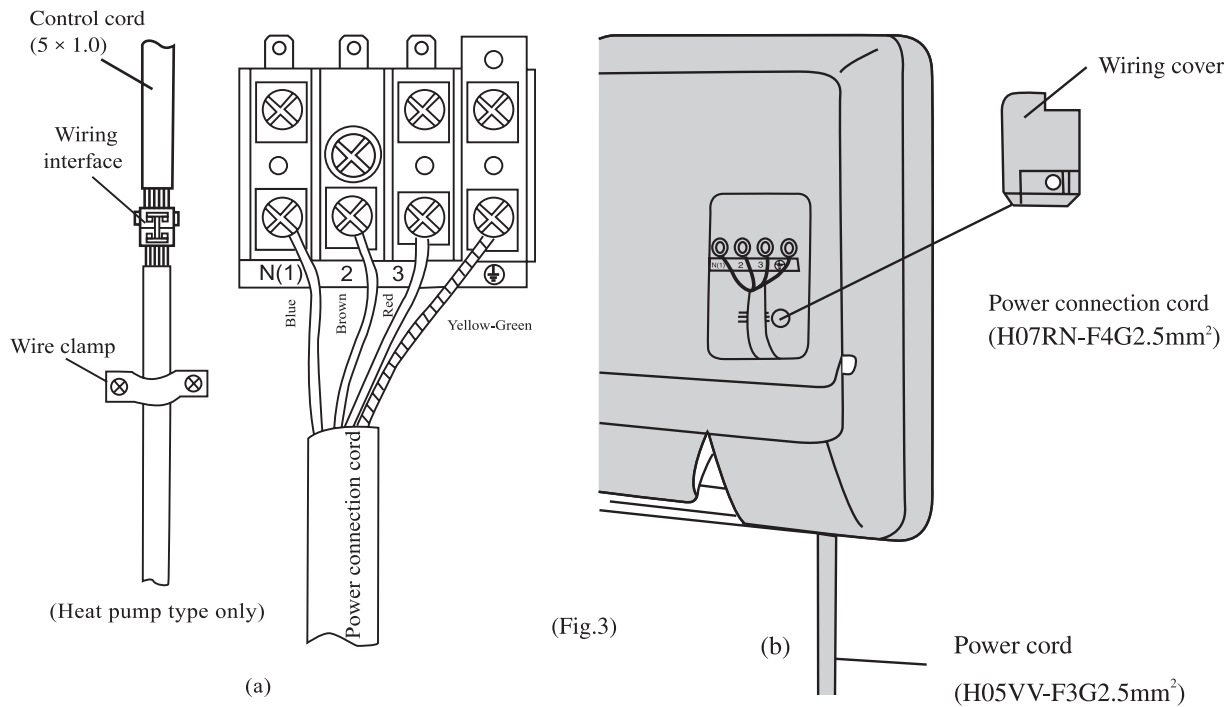

NOTE:

- All the electrical work must be done by qualified personnel according to national wiring regulation and this manual.
- The power supply is type Y connection. If the supply cord is damaged, it must be replaced by the manufacturer or its service agent or a similarly qualified person in order to avoid a hazard.
- The rated voltage and the exclusive circuit must be used.
- Leakage circuit - breaker and air switch of correct capacity must be installed. The air switch of 10A should be used in models below 2500W cooling capacity (including 2500W), and that of 16A should be used in models above 2500W capacity.

Install the indoor unit

1. When routing the piping and wiring from the left or right side of the indoor unit, cut off the tailings from the chassis in necessary (shown in Fig.4)
 - Cut off the tailings when routing the wiring only.
 - Cut off the tailings and tailings 2 when routing both the wiring and piping.
2. Wrap the piping and wiring and pull them through the cut-off-tailings hole (shown in Fig. 5).
3. Hang the 2 mounting slots of the indoor unit on the upper tabs of the real panel and check if it is firm enough.
4. The height of the installed location should be 2.3m or more from the floor.

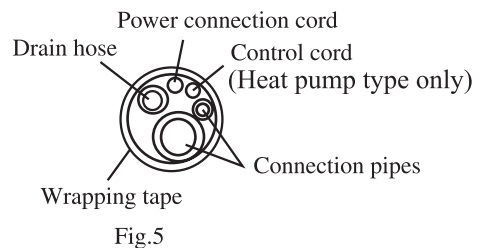
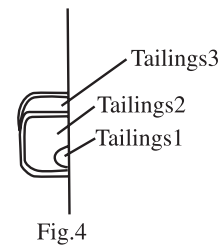

Install the outdoor unit

● Install the connection pipe

1. Align the center of the piping flare with the relevant valve.
2. Screw in the flare nut by hand and then tighten the nut with spanner and torque wrench.

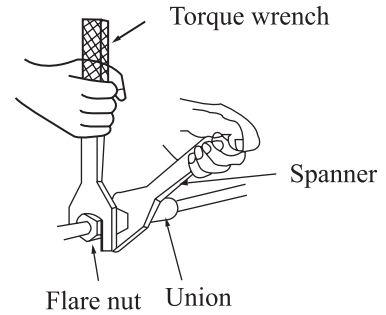

Note: Exceeding tightening torque will damage the flare surface. Tightening torque table

Hex nut diameter (mm)	Tightening torque (N.m)
Ø6	15 – 20
Ø9.5	31 – 35
Ø12	50 – 55

● Electric wiring connection

1. Disassemble the front-side plate.
2. Remove the tailings of the wiring hole on the right-side plate and install the wire ring in the hole.
3. Route the wiring into the outdoor unit through the wire ring.
4. Connect the power connection cord to the wiring terminal board with screws, make sure that the wiring connection is in accordance with the indoor unit's and the earth wire must be connected securely.
5. For the heat pump type, connect the control cord (5x1.0) to the outdoor unit through the relevant interface.
6. Fix the wiring with wire clamps.
7. Fix all the wires on the right-side plate with the clasp welded on the plate to avoid the wires from touching with the compressor. (Shown in Fig. 6)
8. Reassemble the front-side plate.

Terminal-Wire table

Terminal	Wire
N(1)	Blue
2	Brown
3	Red
⊕	Yellow-Green

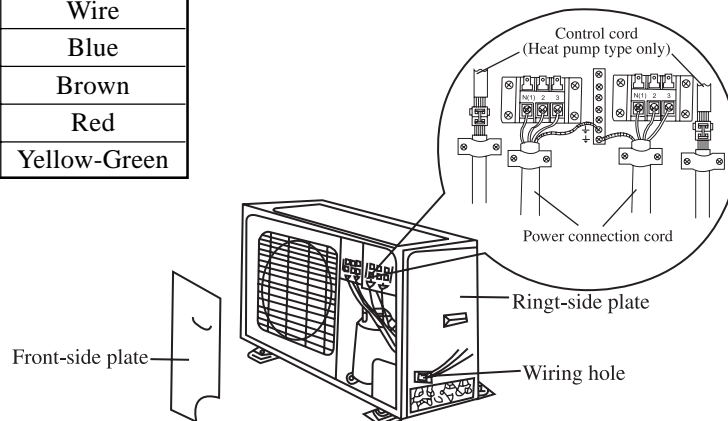

Fig.6

WARNING

- Wrong wiring connection will cause malfunction, electric shock or fire.
- Do not pull the wire forcefully when fixing it with wire clamp.

● Air purging and leakage test

- 1.Remove the flare nuts from the cut-off valves of the outdoor unit.
- 2.Align the center of the piping flare with the relevant valve, and screw in the flare nut about 3 – 4 turns by hand.
- 3.Tighten the flare nut with spanner and torque wrench.
- 4.Remove the valve caps of the gas valve and liquid valve and the service port nut.
- 5.Loosen the valve stem of the liquid valve with a hex wrench.
- 6.Push the check valve core of the gas valve to discharge air and moisture remaining in the refrigerant system.
- 7.Stop pushing the valve core as soon as the refrigerant starts to be discharged, and reinstall the service port nut.
- 8.Open the liquid valve and gas valve entirely (shown in Fig.7).
- 9.Tighten the valve caps and test leakage at all joints of the piping (both indoor and outdoor) with liquid soap or leak detector.
- 10.If possible, discharge air and moisture remaining in the refrigerant system with a vacuum pump. (shown in Fig.8)

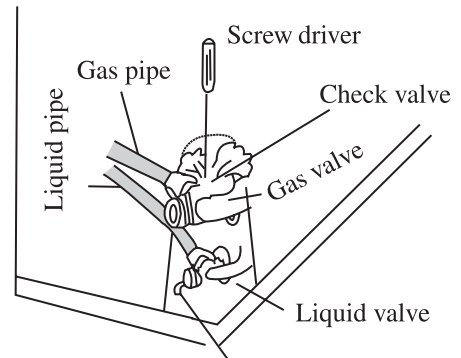

Fig.7

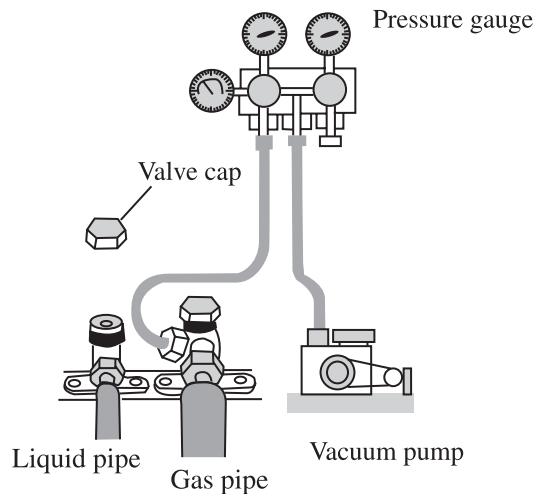

Fig.8

● Outdoor condensation drainage (Heat pump type only)

When the unit is heating or defrosting, the waste water formed in the outdoor unit can be drained out reliably through the drain hose.

Installation:

Install the outdoor drain elbow in the $\varnothing 25$ hole on the base plate as shown in Fig.9, and joint the drain hose to the elbow, so that the waste water formed in the outdoor unit can be drained out to a proper place.

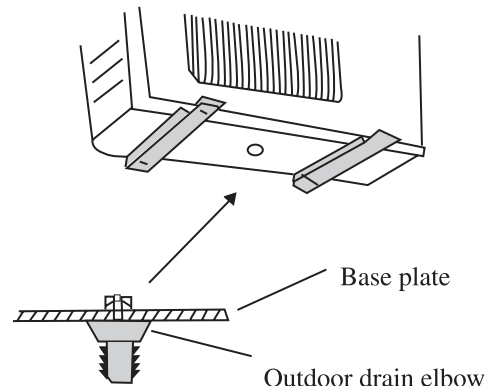

Fig.9

Test operation and check after installation



● Test operation

1. Before test operation

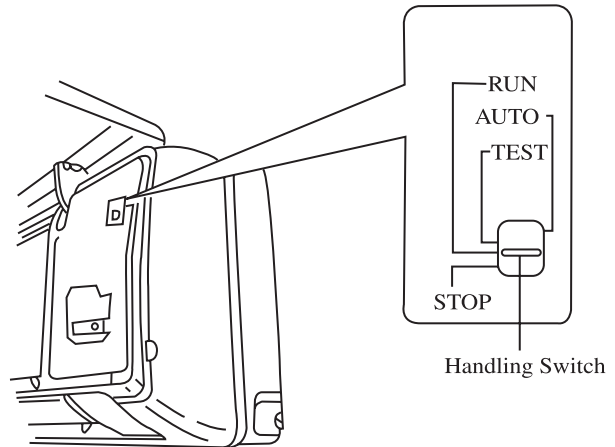
- (1) Do not switch on power before installation is finished completely.
- (2) Electric wiring must be connected correctly and securely.
- (3) Cut-off valves of the connection pipes should be opened.
- (4) All the impurities such as scraps and thrums must be clear from the unit.
- (5) Open the surface panel and set the handling switch to “RUN” mode.



2. Test operation method

- (1) Switch on power and press “1/0” button on the remote controller.
- (2) Press “MODE” button and check the operation condition of  ,  ,  modes.
- (3) Forced operation.

Act as following when the remote controller can not be used:

- (1) At stopping, set the handling switch to “AUTO” mode, then the unit will automatic run in the mode selected by the microcomputer system according to surrounded temperature.
- (2) At operation, set the handling switch to “STOP” mode to turn off the unit.

NOTE : The “TEST ” mode is only for testing, do not set the switch to this mode at normal operation.

● Check after installation

Items to be checked	Possible mal-function	Situation
Has it been fixed firmly?	The unit may drop, shake or emit noise.	
Have you done the refrigerant leakage test?	It may cause insufficient refrigerating capacity.	
Is heat insulation sufficient?	It may cause condensation and dripping.	
Does the unit drain well?	It may cause condensation and dripping.	
Is the voltage in accordance with the rated voltage marked on the nameplate?	It may cause electric mal-function or damage the part.	
Is the electrical wiring and piping connection installed correctly and securely?	It may cause electric mal-function or damage the part.	
Has the unit been connected to a secure earth connection?	It may cause electrical leakage.	
Is the power cord specified?	It may cause electric mal-function or damage the part.	
Has the inlet and outlet been covered?	It may cause insufficient refrigerating capacity.	
Has the length of connection pipes and the refrigerant capacity been record?	The refrigerant capacity is not accurate	

Wiring diagram

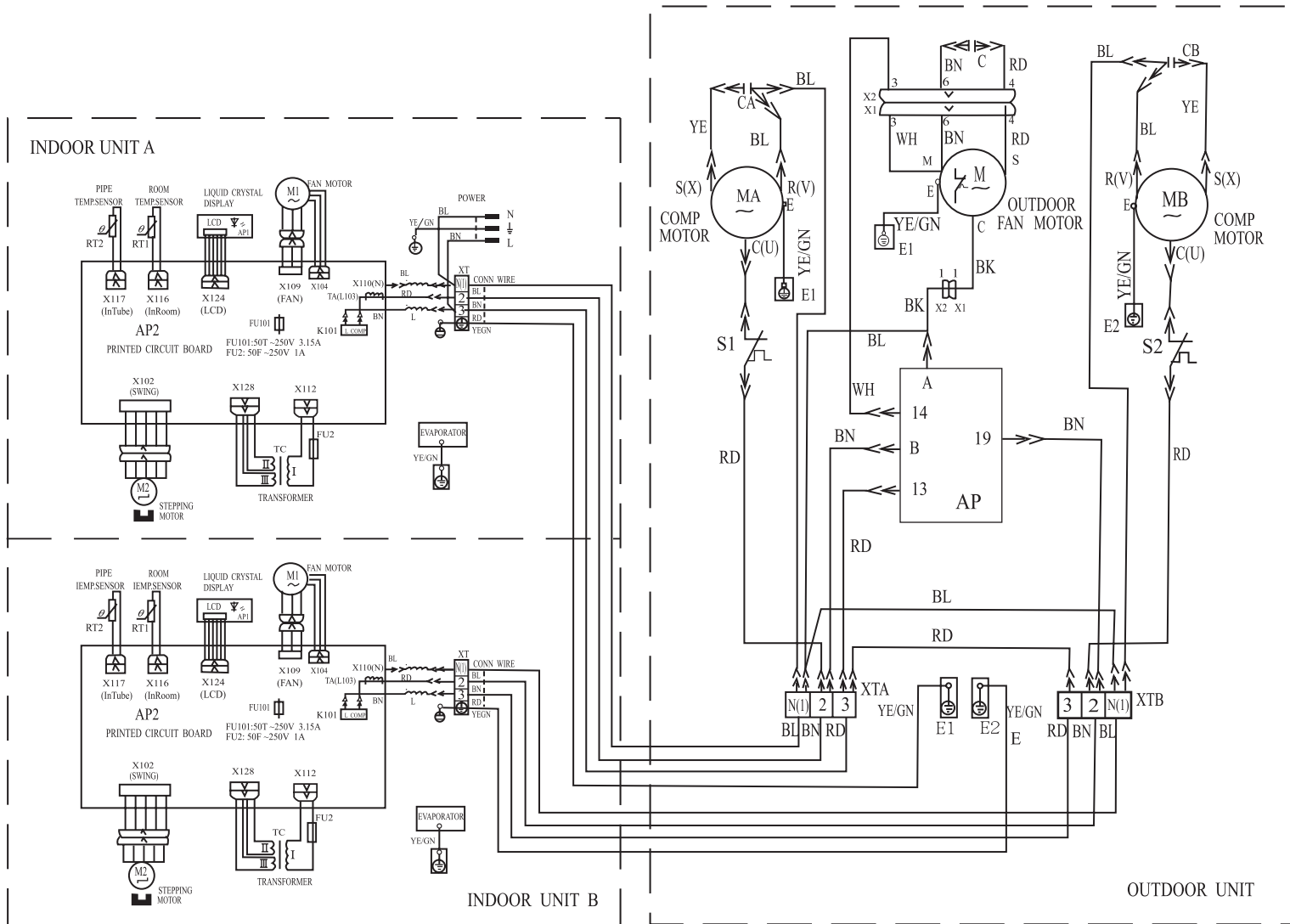

Note: This diagram is just for reference only, the accurate diagram is labeled on the units you bought.

CONTENT

Operation and maintenance	The instructions before use		1	
	Name and function of each part		3	
	Remote Control operation procedure	Name and function - Remote control		4
		Name and function - Remote control (Remove the cover)		5
		COOL mode operation procedure		6
		HEAT mode operation procedure		7
		DRY mode operation procedure		8
		AUTO mode operation procedure		9
		TIMER mode operation procedure		10
		SLEEP mode operation procedure		11
		How to install batteries		12
		User notices		13
	Care and maintenance		14	
	Troubleshooting		16	
	Technical specifications		18	
Accessories and Installation diagram		20		
Installation	Installation location		22	
	Install the indoor unit		23	
	Install the outdoor unit		25	
	Test operation and check after installation		27	
	Electrical wiring diagram		28	

Thank you for choosing MUNDOCLIMA Air conditioner, please keep this owner's manual carefully for consultation.